

CATALOGO 2017



CROMIE STANDS OUT FOR ITS 100% MADE IN ITALY PRODUCTION.

It is a **creative laboratory** rooted in the heart of Emilia and finds its main inspiration in the city of Bologna which is considered by many the cradle of ideas and innovation in the mechanical field. The project started in 1998. **Key-points of this project are the persons involved, motivated by devotion and accuracy, and the technology used to broaden the horizons towards the most exclusive design.** The project is based on the passion to create a product line whose modern and refined design combined with technical perfection results in furniture for **floors and coverings** allowing to "create your own indoor space: beautiful, comfortable and most of all unique". The main characters of this story are strongly bound to the "**Made in Italy**" concept. An Italian entrepreneur with a background in the mechanical field whose core business has always been focused on Aluminium smelting and processing.

The product quality is constantly guaranteed by **Made in Italy** processing.

CROMIE EST UNE RÉALITÉ CARACTÉRISÉE PAR LE MADE IN ITALY AU 100 %.

C'est un **laboratoire créatif** qui plonge ses racines dans le cœur de l'Émilie et trouve sa lymphe vitale dans la ville de Bologne considérée par beaucoup de gens le berceau des idées et de l'innovation mécanique. Le projet commence à prendre vie en 1998. **Les protagonistes sont les personnes, encouragées par le dévouement et la précision, et la technologie qui ouvre ses horizons pour soutenir le design le plus exclusif.** À la base de tout cela il y a la passion de créer une ligne de produits où le design moderne et recherché se marie avec la perfection technique, donnant vie à des compléments de décoration pour **sol et revêtement** qui permettent de « créer un intérieur beau, accueillant et surtout personnalisé ». Un fort lien avec le « **Made in Italy** » caractérise les protagonistes de cette histoire. Un entrepreneur italien avec un background de type mécanique, dont le core business a été toujours orienté au monde de la fusion et du façonnage de l'**Aluminium**.

La qualité des produits est constamment garantie par les façonnages **Made in Italy**

È UNA REALTÀ AL 100% MADE IN ITALY.

E' un laboratorio creativo che pone le sue radici nel cuore dell'Emilia e trova la sua linfa vitale nella città di Bologna considerata da molti la culla delle idee e dell'innovazione meccanica.

IL PROGETTO INIZIA A PRENDERE VITA NEL 1998.

Protagonisti sono le persone, motivate da dedizione e precisione, e la tecnologia che amplia i propri orizzonti a supporto del più esclusivo design.

Alla base di tutto vi è la passione di creare una linea di prodotti in cui il design moderno e ricercato si sposi con la perfezione tecnica, dando vita a complementi d'arredo per pavimento e rivestimento che consentano di "costruire il proprio indoor bello, accogliente e soprattutto personale."

Un forte legame al "**Made in Italy**" si trova nei protagonisti di questa storia.

Un imprenditore italiano con un background di stampo meccanico, il cui core business è sempre stato orientato al mondo della fusione e lavorazione dell'Alluminio.

La qualità dei prodotti è costantemente garantita dalle lavorazioni **Made in Italy**.

PRIVACY & LEGAL

2017 © Cromie (All right reserved. 10545-7)

QUALITY AND FINISHING

The **aluminium** is a widely known metal used in the building, indoor and outdoor furniture fields because of its great processing properties as well as the wide range of possible surface finishing and colouring.

There are mainly 4 types of finishing operations that we can perform on all products:

- **Polishing:** to give the surface a polished aspect
- **Glazing:** to give the surface a glazed / matt aspect
- **Sandblasting** and micro shot-peening: to give the surface an "antique" and at the same time modern aspect. In particular, on glossy colours it creates charming "nuances"
- **Brush Scratching:** a "Random" finishing that allows obtaining unique items.

The colouring process is mainly performed by **Anodizing** or manual application of two-component neutral and coloured (Gloss range) Resins that keep the product aspect over time.

Our company uses only the 6060 series **Aluminium** alloy that ensures the best aesthetic and quality result during the Anodizing phase.

We use exclusively certified **Aluminium**.

 **The Aluminium is 100% recyclable**

QUALITÉ ET FINITIONS

L'**aluminium** est un **métal** désormais très connu, il est utilisé dans le secteur des constructions, de la **décoration** d'intérieur et extérieur, ayant de très bonnes caractéristiques de façonnage et une grande possibilité de finition superficielle et de coloration.

Les finitions que nous opérons, pouvant être appliquées sur tous les produits, sont surtout 4

- **Polissage:** pour donner à la surface un aspect poli
- **Satinage:** pour donner à la surface un aspect satiné / mat
- **Sablage** et micro-grenailage: confère à la surface un aspect « antique » et en même temps moderne, de manière particulière dans les colorations brillantes forme des « réflexions » de lumière beaucoup suggestives
- **Griffure Brush:** elle est réalisée au hasard et chaque particulier est unique

Les « colorations » sont réalisées surtout à travers **l'Anodisation** ou l'application manuelle des résines à deux composants neutres et colorées (série Gloss) qui rend les produits inaltérables dans le temps

L'alliage d'**Aluminium** que nous utilisons est exclusivement la série 6060 qui garantit en phase d'Anodisation le meilleur résultat en termes d'esthétique et qualité.

Nous utilisons uniquement de **l'Aluminium** certifié

 **L'Aluminium peut être recyclé au 100 %**



QUALITÀ E FINITURE.

Le finiture che eseguiamo, possono essere fatte su tutti i prodotti, sono principalmente 4:

- **Lucidatura:** per dare alla superficie un'aspetto lucido
- **Satinatura:** per dare alla superficie un'aspetto satinato / opaco
- **Sabbatura e micropallinatura:** conferisce alla superficie un'aspetto "antico" e allo stesso tempo moderno in particolare nelle colorazioni lucide forma "riflessi" di luce molto suggestivi
- **Graffiatura Brush:** viene eseguita Random e ogni particolare è unico

Le "colorazioni" sono eseguite principalmente mediante **Anodizzazione** o applicazione manuale di Resine bi componenti neutre e colorate (serie Gloss e Glitter) che conferisco ai prodotti garanzia di inalterabilità nel tempo.

La Lega di **Alluminio** da noi utilizzata è esclusivamente la serie 6060 che garantisce in fase di Anodizzazione il massimo risultato estetico e di qualità.

Usiamo solo e esclusivamente Alluminio certificato.

 **L'Alluminio è riciclabile al 100 %**





TILETECH - PAVIMENTO & RIVESTIMENTO - 8 mm

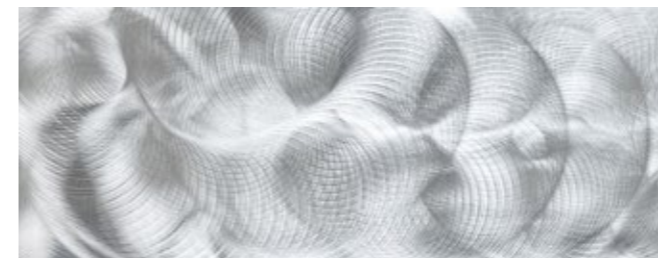

BRUSH NEUTRA



POLISHED NEUTRA

F.ti	25X100	25X25
	25X75	25X50

FINITURA BRUSH O POLISHED (COLORE ALLUMINIO)

ART.	FORMATO	Pz/Mq	€/Pz	Pz/Scat.	Kg/Scat.
Item	Size	Pcs/mt	€/pcs	Pcs/Box	Kg/Box
20.2525	25x25 cm – 10" x 10"	16	Cod.Prezzo 73	12	7,5
20.2550	25x50 cm – 10" x 20"	8	Cod.Prezzo 108	8	10
20.2575	25x75 cm – 10" x 30"	5,33	Cod.Prezzo 140	4	7,5
20.2510	25x100 cm – 20" x 40"	4	Cod.Prezzo 160	4	10
	FINITURA COLORI GLOSS + €/Mq		Cod.Prezzo 71		

CARATTERISTICHE TECNICHE

- TEST ESEGUITI PRESSO CENTRO CERAMICO BO. RAPP. 3560/13 e 35601/13
 - Materiale: Lega Primaria in ALLUMINIO EN AW 6082 -5774 - CERTIFICATA



TILETECH - PAVIMENTO & RIVESTIMENTO - 3 mm

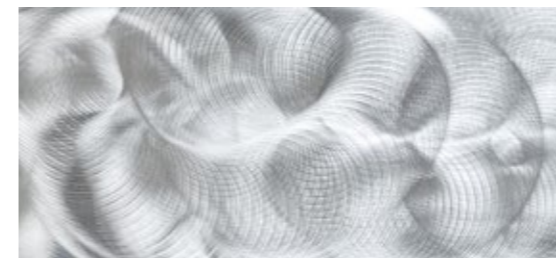

BRUSH NEUTRA



POLISHED NEUTRA

F.ti	60x120 cm	60x60 cm
	30x120 cm	30x60 cm
		15x60 cm

FINITURA BRUSH O POLISHED (COLORE ALLUMINIO)

ART.	FORMATO	Pz/Mq	€/Pz	Pz/Scat.	Kg/Scat.
Item	Size	Pcs/mt	€/pcs	Pcs/Box	Kg/Box
	15x60 cm - 6" x 24"	11,1	Cod.Prezzo 91	12	10
	30x60 cm - 12" x 24"	5,5	Cod.Prezzo 133	8	12,8
	30x30 cm - 12" x 12"	11,1	Cod.Prezzo 88	12	10
	60x60 cm - 24" x 24"	2,78	Cod.Prezzo 169	4	12,8
	30x120 cm - 12" x 48"	2,78	Cod.Prezzo 170	4	12,8
	60x120 cm - 24" x 48"	1,38	Cod.Prezzo 190	2	12,8
	FINITURA COLORI GLOSS + €/Mq		Cod.Prezzo 71		

CARATTERISTICHE TECNICHE

- TEST ESEGUITI PRESSO CENTRO CERAMICO BO. RAPP. 3560/13 e 35601/13
 - Materiale: Lega Primaria in ALLUMINIO EN AW 6082 -5774 - CERTIFICATA

SLIMTECH - RIVESTIMENTO - 3 mm



BRUSH NEUTRA



POLISHED NEUTRA

FINITURA BRUSH O POLISHED (COLORE ALLUMINIO)

ART.	FORMATO	Pz/Mq	€/Pz	Pz/Scat.	Kg/Scat.
Item	Size	Pcs/mt	€/pcs	Pcs/Box	Kg/Box
	15x60 cm - 6" x 24"	11,1	Cod.Prezzo 91	12	10
	30x60 cm - 12" x 24"	5,5	Cod.Prezzo 133	8	12,8
	30x30 cm - 12" x 12"	11,1	Cod.Prezzo 88	12	10
	60x60 cm - 24" x 24"	2,78	Cod.Prezzo 169	4	12,8
	30x120 cm - 12" x 48"	2,78	Cod.Prezzo 170	4	12,8
	60x120 cm - 24" x 48"	1,38	Cod.Prezzo 190	2	12,8
FINITURA COLORI GLOSS + €/Mq			Cod.Prezzo 71		

CARATTERISTICHE TECNICHE

- TEST ESEGUITI PRESSO CENTRO CERAMICO BO. RAPP. 3560/13 e 35601/13
 - Materiale: Lega Primaria in ALLUMINIO EN AW 6082 -5774 - CERTIFICATA

F.ti	60X120 cm	60X60 cm
	30x120 cm	30x60 cm
		15x60 cm

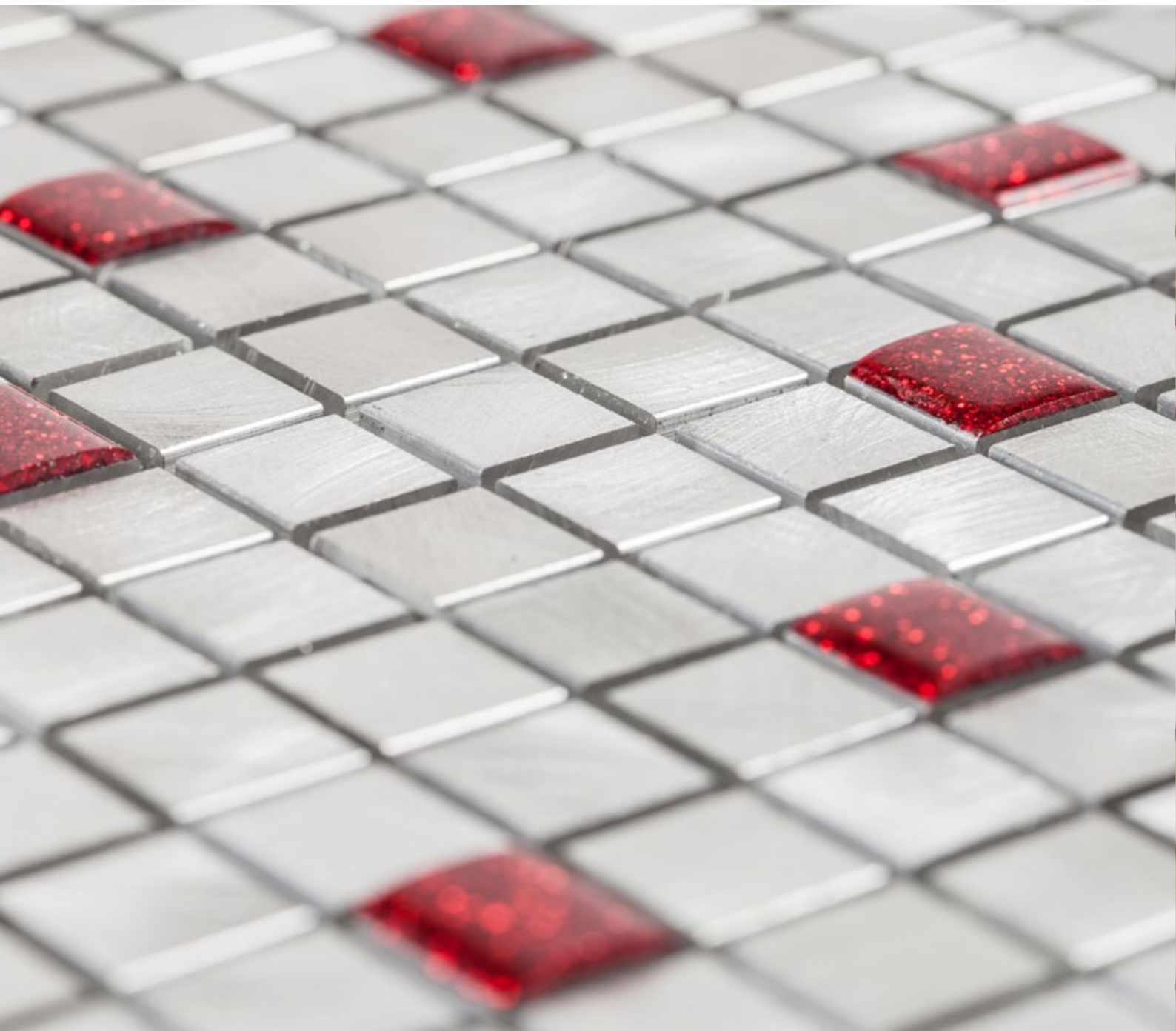

MOSAICO MURETTO

30X30 CM - **TESSERA 1,5X3 X H 0,8** - PZ/SCAT. 6 - Kg. 6



Art.11.1500 - **BRUSH**

Cod.Prezzo 134

MOSAICO MURETTO MAXI

30X30 CM - H 0,8 - PZ/SCAT. 6 - Kg. 6



Art.11.1520 - **BRUSH**

Cod.Prezzo 134



Art.11.1506 - **MIX BRONZO**

Cod.Prezzo 151



Art.11.1560 - **MIX ARGENTO**

Cod.Prezzo 150



Art.11.1505 - **MIX GREY**

Cod.Prezzo 151



Art.10.1520 - **GOCCE DI LUCE**

Cod.Prezzo 159

MOSAICO SCACCHIERA - 1.5 X 1.5 cm

30X30 CM - **TESSERA 1,5X1,5 X H 0,8** - PZ/SCAT. 6 - Kg. 6

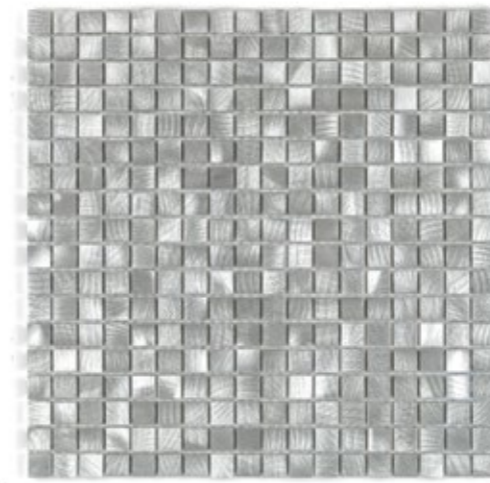

Art. 10.1500 - **BRUSH**

Cod.Prezzo 148

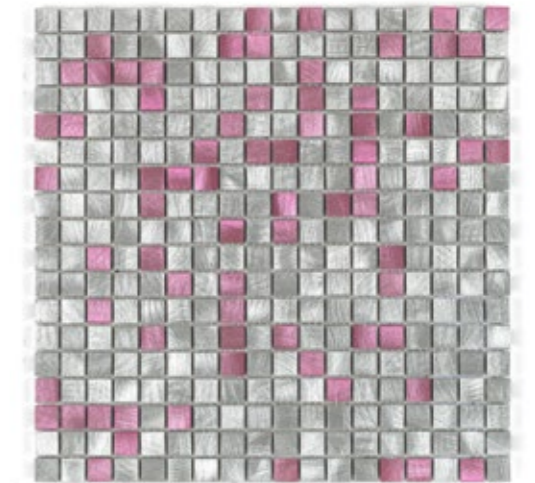

Art. 10.1503 - **GOCCE DI ROSA**

Cod.Prezzo 158

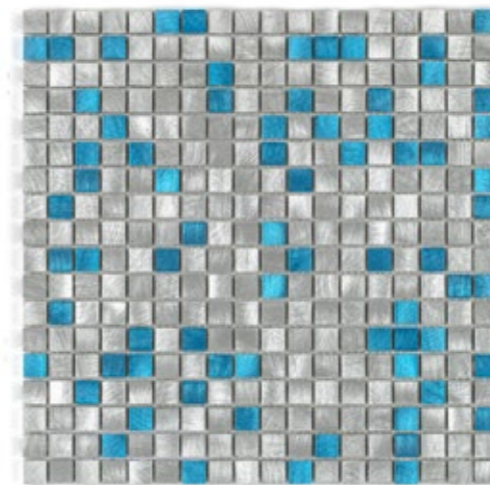

Art. 10.1504 - **GOCCE DI MARE**

Cod.Prezzo 158

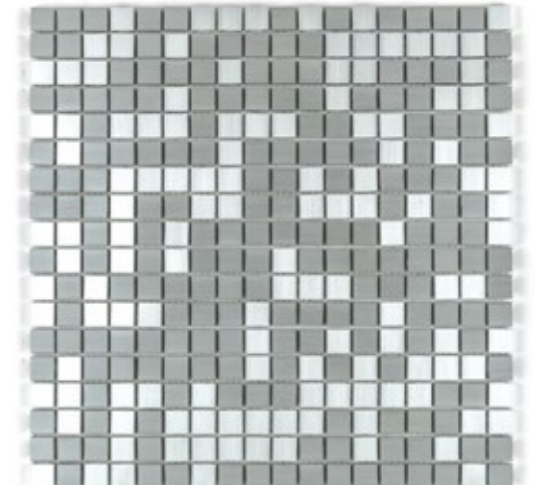

Art. 10.1510 - **ARG.SAT.**

Cod.Prezzo 160

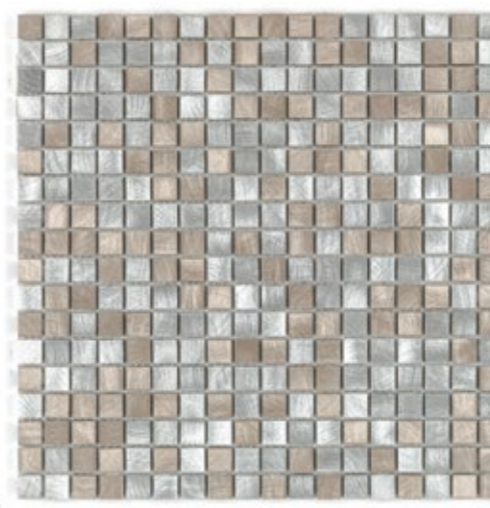

Art. 10.1508 - **MIX BRONZO**

Cod.Prezzo 158



Art. 10.1506 - **MIX GREY**

Cod.Prezzo 158

MOSAICO - 2 X 2 cm

30X30 CM - TESSERA 2X2 X H 0,9 - PZ/SCAT. 6 - Kg. 6

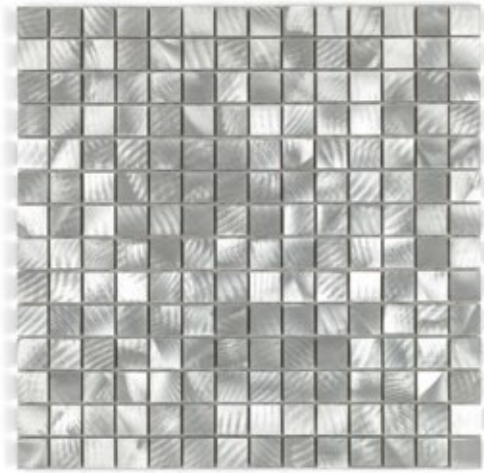

Art.10.2000 - **BRUSH** Cod.Prezzo 144

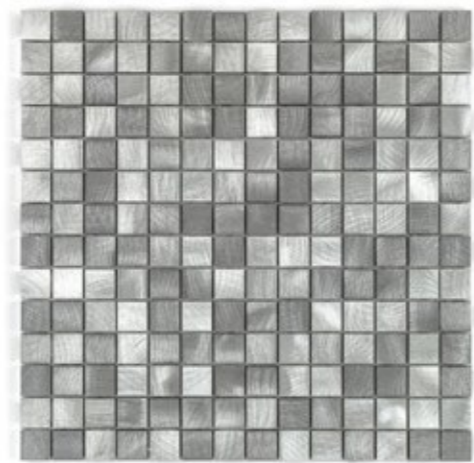

Art.10.2006 - **MIX GREY** Cod.Prezzo 157

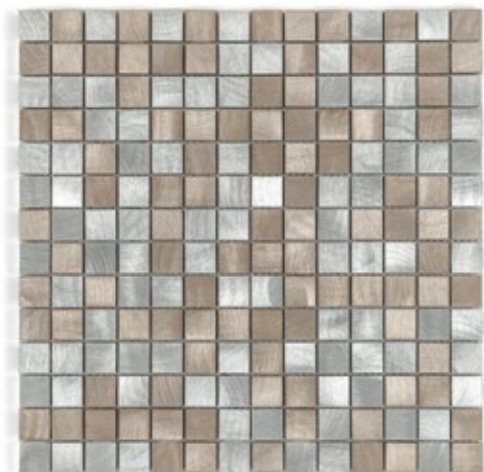

Art.10.2008 - **MIX BRONZO** Cod.Prezzo 157

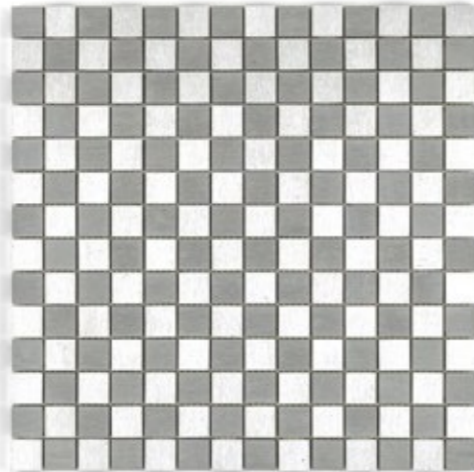

Art.10.2021 - **DAMA LEVIGATO** Cod.Prezzo 165

30X30 CM - H 0,8 - PZ/SCAT. 6 - Kg. 7



Art.12.0002 - **TENDINA BRUSH** Cod.Prezzo 110



Art. 14.1500 - **BRUSH 1.5 3D** Cod.Prezzo 172



Art.10.3000 - **BRUSH 3X3** Cod.Prezzo 123

MOSAICO MURETTO ANODIZZATO

30X30 CM - H 0,8 - PZ/SCAT. 6 - Kg. 6



Art.11.1540 - **MIX OX BRONZO** Cod.Prezzo 152



Art.11.1530 - **MIX OX GREY** Cod.Prezzo 158

MOSAICO MURETTO GLOSS

30X30 CM - H 0,8 - PZ/SCAT. 6 - Kg. 6



Art.11.1570 - **MIX GLOSS BRONZO** Cod.Prezzo 149



Art.11.1580 - **MIX GLOSS GRAY** Cod.Prezzo 149

30X30 CM - H 0,8 - PZ/SCAT. 6 - Kg. 7

MINI STICK

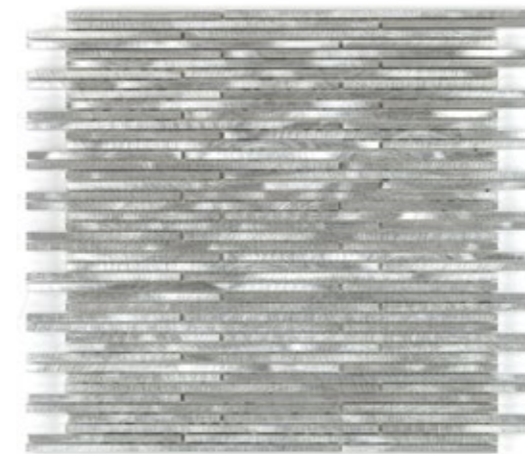

Art.13.0002 - **BRUSH**

Cod.Prezzo 154



Art.13.0001 - **MIX.BRUSH**

Cod.Prezzo 168

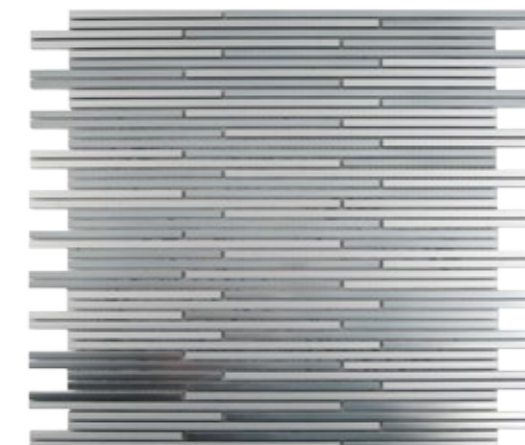

rt. 13.0003 - **MIX ARGENTO**

Cod.Prezzo 165



Art.13.0004 - **BRONZO**

Cod.Prezzo 172



Art.13.0005 - **MIX BRONZO**

Cod.Prezzo 175

SERIE GLITTER



30X30 CM - TESSERA 1,5X1,5 - PZ/SCAT. 6 - Kg. 6

Le finiture dei mosaici GLITTER sono puramente dimostrative, in quanto sono fornibili nella finitura desiderata. Specificare il codice colore Glitter richiesto.

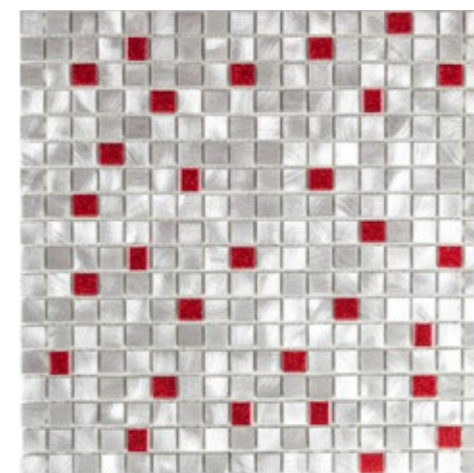

Art.01.1500 - Cod. Colore **07-RED** Cod.Prezzo 171



Art.01.1500 - Cod. Colore **26-BURNISHED** Cod.Prezzo 171



Art.01.1000 - Cod. Colore **26-BURNISHED** Cod.Prezzo 165



Art.01.1000 - Cod. Colore **01-SILVER** Cod.Prezzo 165



Art. 13.0000 **MINI STICK MIX GLITTER** Cod.Prezzo 170

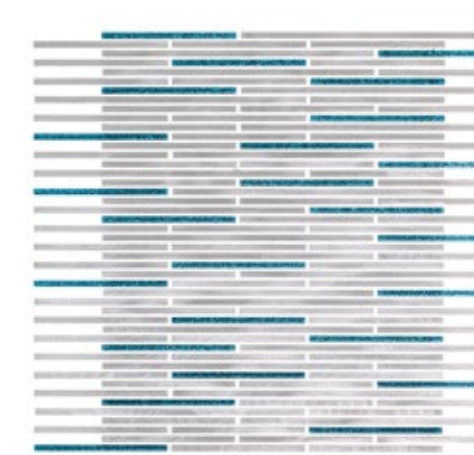

Art. 13.0000 **MINI STICK AZZURRO 08** Cod.Prezzo 168

FASCE GLITTER

PZ/SCAT. 6

MINISTIK GLITTER 1.2X30

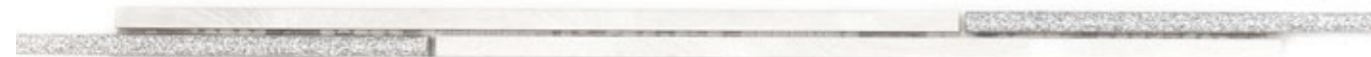

Serie 06.0000 Fascia MINISTICK GLITTER - 1,2X30 cm

Cod. Prezzo 52

FASCIA MURETTO GLITTER 2.2X30



Serie 06.1000 Fascia GLITTER - 2,2X30 cm

Cod. Prezzo 52

FASCIA MURETTO GLITTER 4.5X30

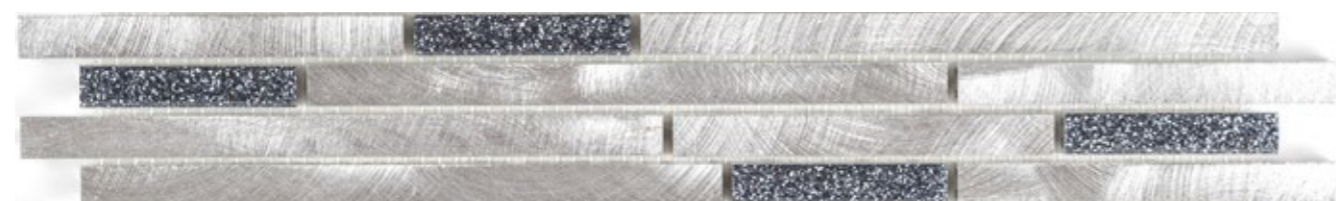

Serie 06.2000 Fascia Glitter -4.5x30

Cod.Prezzo 81

FASCIA SCACCHIERA GLITTER 3X30



Serie 06.3000 Fascia Scacchiere Glitter -3x30

Cod.Prezzo 55

Le finiture delle Fasce GLITTER sono puramente dimostrative, in quanto sono fornibili nella finitura desiderata. **Specificare il codice colore Glitter richiesto**

FINITURE GLITTER

Codice finiture



Articolo	Finitura	Formato Cm	Lunghezza cm	Cod.Prezzo/Pz	Pz/scat.	Kg/scat.
Item	Finish	Size	Extent	Price code/pc	Pcs/box	Kg/Box
01.0605	GLITTER	0,5x0,8 cm	60	47	10	0,9
01.1005	GLITTER		100	69	10	1,5
01.2005	GLITTER		200	107	10	3
01.0610	GLITTER	1x0,8 cm	60	49	8	0,7
01.1010	GLITTER		100	70	8	1,2
01.2010	GLITTER		200	109	8	2,4
01.0615	GLITTER	1,5x0,8 cm	60	64	6	0,8
01.1015	GLITTER		100	85	6	1,3
01.2015	GLITTER		200	132	6	2,5

PROFILI PER ANGOLI GLITTER

Finitura	Cm 60	Cm 100	Cm 200
	Cod.Prezzo	Cod.Prezzo	Cod.Prezzo
GLITTER (come da tabella colori)	61	80	123
Kg/Box	0,7	1,0	2,0
Pz/Box	6	6	6

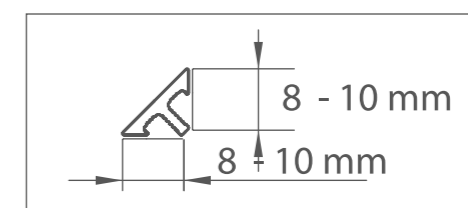

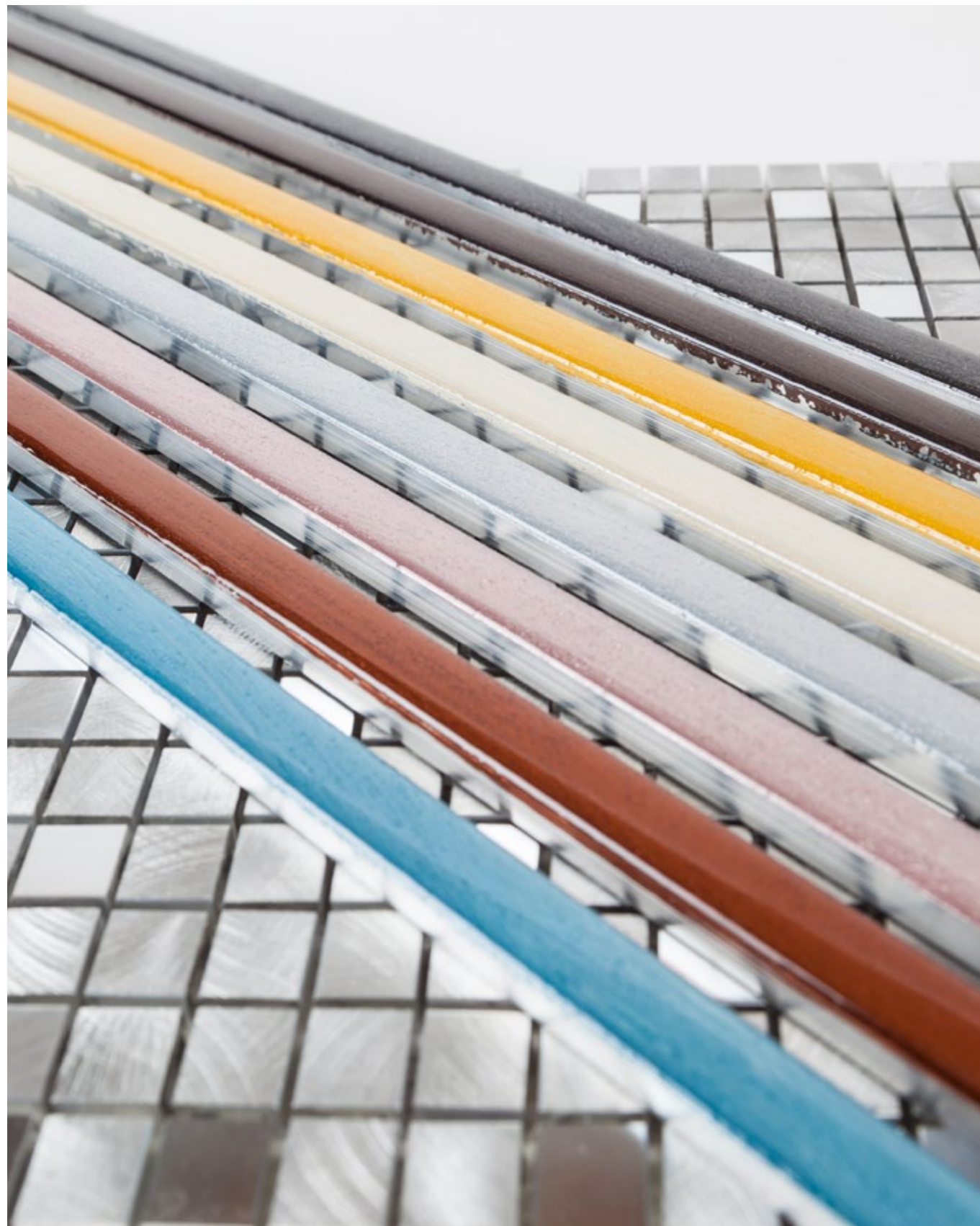

Nature N.750 - BEIGE CHIARO - Formato 1.5x100 cm



Nature N.190 - ORO - Formato 1.5x100 cm



Nature N.729 - ROSA - Formato 1.5x100 cm



Nature N.710 - RAMATO - Formato 1.5x100 cm



Nature N.715 - MARRONE - Formato 1.5x100 cm



Nature N.732 - AZZURRO - Formato 1.5x100 cm



Nature N.170 - ARGENTO - Formato 1.5x100 cm



N.716 - ANTRACITE - Formato 1.5x100 cm

Caratteristiche

LIST. NATURE 1.5X100

Articolo	Finitura	Formato Cm	Lunghezza cm	Cod.Prezzo/Pz	Pz/scat.	Kg/scat.
Item	Finish	Size	Extent	Price code/pc	Pcs/box	Kg/Box
NATURE	A SCELTA	1,5x0,8	100	93	4	1

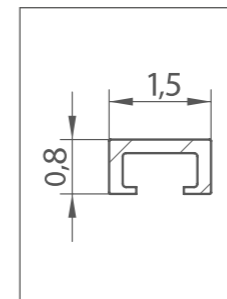







FINITURA BRUSH

F.ti disponibili

			1x0.8	1x1	1.5	2	3
	BRUSH NEUTRO	B.0001	●	●	●	●	●

FINITURE BRUSH + ANODIZZATO

	BRUSH + ARGENTO LUC.	B.0002		●	●		
	BRUSH BRONZO LUC.	B.0003		●	●		
	BRUSH ORO LUC.	B.0005		●	●		
	BRUSH E21 LUC.	B.0004		●	●		
	BRUSH MOKA LUC.	B.0008		●	●		
	BRUSH FUME' LUC.	B.0006		●	●		

FINITURE ANODIZZATE

	ARGENTO SATINATO	S.0002	●	●	●		
	ARGENTO LUCIDO	L.0002	●	●	●		
	BRONZO SATINATO	S.0003	●				
	BRONZO LUCIDO	L.0003	●				
	E21 LUCIDO	L.0004	●				
	MOKA SATINATO	S.0008	●				
	MOKA LUCIDO	L.0008	●				

FINITURE GLOSS

	GLOSS GREY	G.0502	●	●	●	●	●
	GLOSS BRONZO	L.0504	●	●	●	●	●

FINITURE GLOSS: Sono decorati con resine acriliche Neutre e/o Colorate, applicate manualmente, conferiscono al prodotto caratteristiche cromatiche uniche. Differenze di tono e/o finitura sono caratteristiche del prodotto fatto a mano. Durante la posa non utilizzare in nessun caso prodotti abrasivi, acidi o basici, acetone, solventi e diluenti. Non applicare sulla parte decorata Scotch, nastri adesivi o simili

FINITURE GLOSS: ont décorées avec de l'acrylique neutre et / ou de couleur appliqué à la main pour donner au produit des caractéristiques de couleurs uniques. Les différences de ton sont caractéristiques de produit fabriqué à la main. Ne pas utiliser en aucun cas produits abrasifs, acides et basiques, solvants et diluants. Ne pas appliquer sur la surface décoré scotch ou similaire

FINITURE GLOSS: All parts are decorated with acrylic neutral and / or colored resins, hand applied to give the product unique chromatic characteristics. Differences in tones and are characteristic of hand-made products. Do not use in any situation (installation, surfacing and cleaning) abrasive, acid and basic, solvent and diluent products. Do not apply on the decorated part Scotch, adhesive tape or similar.

Caratteristiche

1 X 0,8 cm

MATITA PIATTA 1 cm

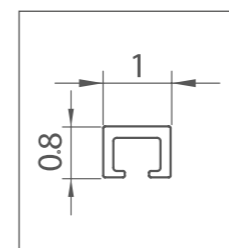

Finitura	Cm 60 Cod.Prezzo	Cm 100 Cod.Prezzo	Cm 200 Cod.Prezzo
BRUSH (B.0001)	29	43	73
GLOSS (Tutti)	36	49	83
Kg/Scatola	0,8	1,4	2,8
MATITA 1x1 Pz/Scatola	8	8	8

Caratteristiche

1 X 1 cm

MATITA PIATTA 1 cm

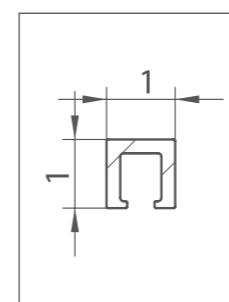

Finitura	Cm 60 Cod.Prezzo	Cm 100 Cod.Prezzo	Cm 200 Cod.Prezzo
BRUSH (B.0001)	29	43	73
ARGENTO SATINATO (S.0002)	29	43	73
ARGENTO LUCIDO (L.0002)	41	54	87
COLORI SATINATI	41	54	87
COLORI LUCIDI	44	61	95
BRUSH + ANODIZZATO (Tutti)	45	62	97
GLOSS (Tutti)	36	49	83
Kg/Scatola	0,8	1,4	2,8
MATITA 1x1 Pz/Scatola	8	8	8

Caratteristiche

1.5 X 0.8 cm

MATITA PIATTA 1.5 cm

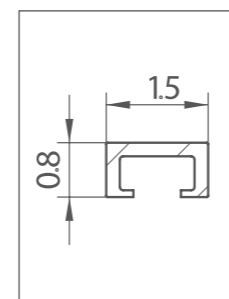

Finitura	Cm 60 Cod.Prezzo	Cm 100 Cod.Prezzo	Cm 200 Cod.Prezzo
BRUSH (B.0001)	29	43	73
ARGENTO SATINATO (S.0002)	29	43	73
ARGENTO LUCIDO (L.0002)	41	54	87
BRONZO SATINATO (B.0003)	41	54	87
BRONZO LUCIDO (L.0003)	44	61	95
BRUSH + ANODIZZATO (Tutti)	45	62	97
GLOSS (Tutti)	36	49	83
Kg/Scatola	0,8	1,4	2,8
Pz/Scatola	6	6	6

Caratteristiche

2 X 0.9 cm

MATITA PIATTA 2 cm

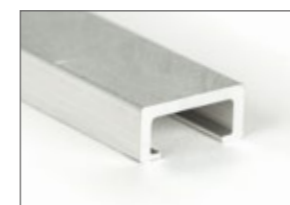
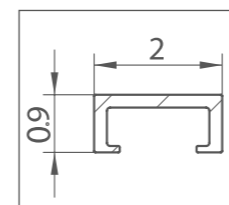

Finitura	Cm 60 Cod.Prezzo	Cm 100 Cod.Prezzo	Cm 200 Cod.Prezzo
BRUSH (B.0001)	35	48	80
ARGENTO SATINATO (S.0002)	35	48	80
ARGENTO LUCIDO (L.0002)	44	61	93
GLOSS (Tutti)	40	56	87
Kg/Scatola	0,6	1,0	2,0
Pz/Scatola	4	4	4

Caratteristiche

3 X 0.8 cm

MATITA PIATTA 3 cm

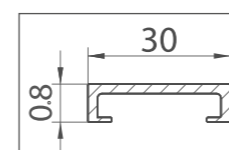





Finitura	Cm 60 Cod.Prezzo	Cm 100 Cod.Prezzo	Cm 200 Cod.Prezzo
BRUSH (B.0001)	42	63	98
GLOSS (Tutti)	51	74	115
Kg/Scatola	0,6	1,0	2,0
Pz/Scatola	4	4	4



FINITURE E COLORI ANODIZZATI

Finiture e colori

COLORI ANODIZZATI STANDARD LUCIDI OMEGA 06

	ARGENTO LUC.	L.0002
	BRONZO LUC.	L.0003
	ORO LUC.	L.0005
	E21 LUC.	L.0004
	FUME' LUC.	L.0006
	MOKA LUC.	L.0008

COLORI ANODIZZATI STANDARD SATINATI OMEGA 06

	ARGENTO SAT.	S.0002
	BRONZO SAT.	S.0003
	ORO SAT.	S.0005
	2003 SAT.	S.0004
	FUME' SAT.	S.0006
	MOKA SAT.	S.0008

FINITURA SABBBIATA + ANODIZZATA OMEGA 06

	SABB. + BRONZO LUC.	SB 03
	SABB. + ARGENTO LUC.	SB 02



Dettaglio finitura Sabbbiata su profilo Omega 06

Caratteristiche

MATITA OMEGA 13R10

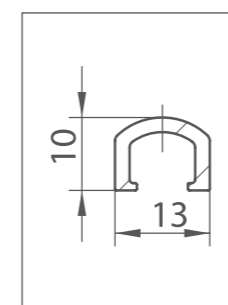

Finitura	Cm 60	Cm 100	Cm 200
	Cod.Prezzo	Cod.Prezzo	Cod.Prezzo
ARGENTO SATINATO (S.0002)	29	43	73
ARGENTO LUCIDO (L.0002)	41	54	87
Kg/Scatola	0,8	1,4	2,8
Pz/Scatola	6	6	6

MATITE OMEGA 06

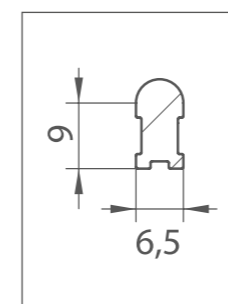

Finitura	Cm 60	Cm 100	Cm 200
	Cod.Prezzo	Cod.Prezzo	Cod.Prezzo
ARGENTO SATINATO (S.0002)	29	43	73
ARGENTO LUCIDO (L.0002)	41	54	87
COLORI SATINATI (Tutti)	41	54	87
COLORI LUCIDI (Tutti)	44	61	95
SABBBIATO + ANODIZZATO	46	63	99
Kg/Scatola	1,0	1,5	3,0
Pz/Scatola	8	8	8

Finitura sabbbiata disponibile Argento e Bronzo

PROFILI PER ANGOLI 1X1 - FINITURA SU 2 LATI

PROFILO 1X1 cm



FINITURE BRUSH 2 LATI



BRUSH NEUTRO B.0001

FINITURE BRUSH + ANODIZZATO



BRUSH + ARGENTO LUC. B.0002



BRUSH BRONZO LUC. B.0003



BRUSH ORO LUC. B.0005



BRUSH E21 LUC. B.0004



BRUSH MOKA LUC. B.0008



BRUSH FUME' LUC. B.0006

Finitura su 2 lati	Cm 60 Cod.Prezzo	Cm 100 Cod.Prezzo	Cm 200 Cod.Prezzo	Tappo 1x1
BRUSH	33	48	79	36
BRUSH + ANODIZZATO	50	66	101	41
ARGENTO SATINATO	33	48	79	41
ARGENTO LUCIDO	43	59	93	41
Kg/Scatola	0,8	1,4	2,8	
Pz/Scatola	8	8	8	2



Caratteristiche

PROFILI PER ANGOLI QUARTER ROUND

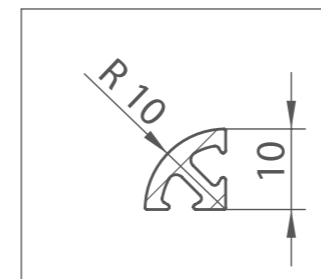

Finitura	Cm 60 Cod.Prezzo	Cm 100 Cod.Prezzo	Cm 200 Cod.Prezzo
ARGENTO SATINATO	31	47	74
ARGENTO LUCIDO	42	57	88
BRONZO SATINATO	36	53	83
BRONZO LUCIDO	44	61	95
Kg/Scatola	0,7	1,0	2,0
Pz/Scatola	6	6	6

TAPPO DI CHIUSURA Cod.Prezzo 41 – Pz Scat. 2

PROFILI PER ANGOLI SLIM 5mm

Caratteristiche

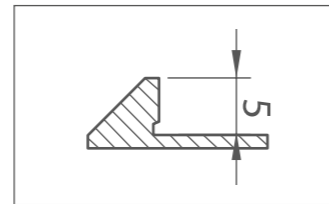
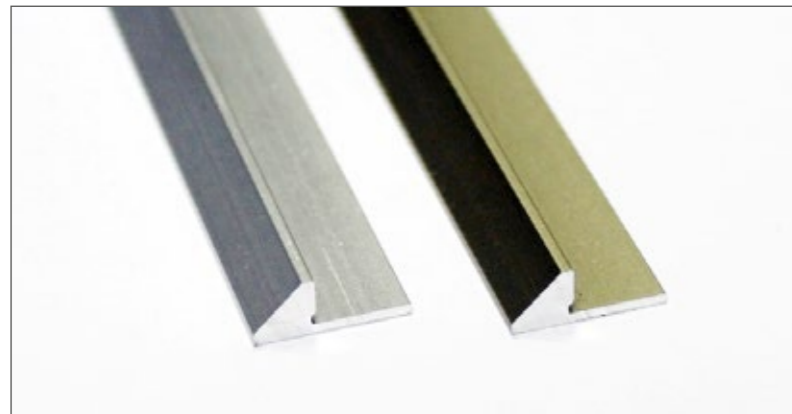

Finitura	Cm 60	Cm 100	Cm 200
	Cod.Prezzo	Cod.Prezzo	Cod.Prezzo
ARGENTO SATINATO	26	41	66
ARGENTO LUCIDO	42	57	88
BRONZO SATINATO	36	53	83
Kg/Scatola	0,7	1,0	2,0
Pz/Scatola	8	8	8

QUARTER ROUND SLIM 3mm

Caratteristiche

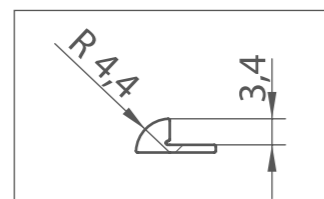

Finitura	Cm 60	Cm 100	Cm 200
	Cod.Prezzo	Cod.Prezzo	Cod.Prezzo
ARGENTO SATINATO	26	41	66
BRONZO SATINATO	36	53	83
Kg/Scatola	0,7	1,0	2,0
Pz/Scatola	8	8	8

PROFILI OTTONE

Caratteristiche

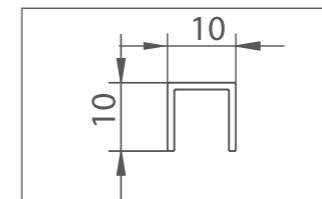
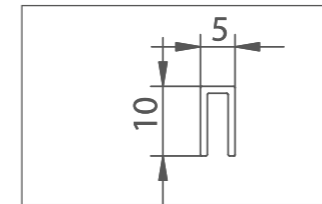

Materiale	Cm 100
	Cod.Prezzo
OTTONE 5 mm	85
OTTONE 10 mm	85
Kg/Scatola	2
Pz/Scatola	6

CARATTERISTICHE TECNICHE

- Ottone UNI EN 1267 Lucido (Brass)

- Idoneo per posa a Pavimento - approprié pour l'installation au sol - Ideal for floor installation

PROFILI ACCIAIO INOX

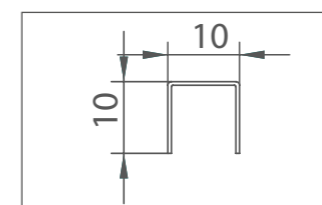
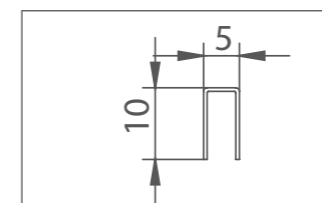

Materiale	Cm 100
	Cod.Prezzo
INOX 5 mm	60
INOX 10 mm	60
Kg/Scatola	1
Pz/Scatola	8

CARATTERISTICHE TECNICHE

Acciaio Inox 316 Lucido

Idoneo per posa a Pavimento - approprié pour l'installation au sol - Ideal for floor installation



Caratteristiche

PROFILI PER ANGOLI IN ACCIAIO INOX



Formato



Articolo	1 barra	1 tappo
	Cod.Prezzo	Cod.Prezzo
QUADRO 10 mm LUCIDO	92	51
QUADRO 10 mm SATINATO	96	49
QUADRO 12 mm LUCIDO	94	53
QUADRO 12 mm SATINATO	100	51
Pezzi Scatola	16	4
Kg Scatola	14	0,2

Formato



Articolo	1 barra	1 tappo
	Cod.Prezzo	Cod.Prezzo
Q. ROUND 10 mm LUCIDO	92	49
Q. ROUND 10 mm SATINATO	96	47
Q. ROUND 12 mm LUCIDO	94	51
Q. ROUND 12 mm SATINATO	100	49
Pezzi Scatola	16	4
Kg Scatola	14	0,2

CARATTERISTICHE TECNICHE

LUNGHEZZA BARRE 250 cm
MATERIALE ACCIAIO INOX 304
SPESSORE 1 mm

PIATTINE

Caratteristiche

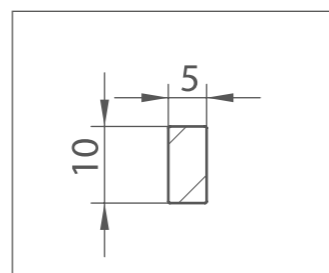
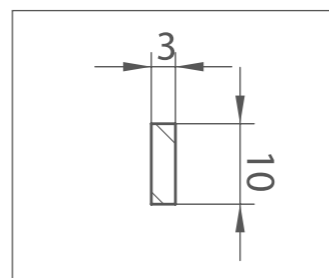

PIATTINA 0,3 X 1 cm - 0,5 X 1 cm

Finitura	Cm 60	Cm 100	Cm 200
	Cod.Prezzo	Cod.Prezzo	Cod.Prezzo
BRUSH NEUTRO	19	32	61
ARGENTO SATINATO	19	32	61
ARGENTO LUCIDO	31	46	76
Kg/Scatola	0,8	1,4	2,8
PIATTINA 0,3x1 Pz/Scatola	18	18	18
PIATTINA 0,5x1 Pz/Scatola	10	10	10

PROFILI SLIM

Caratteristiche

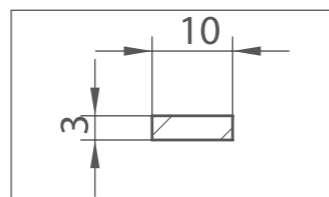
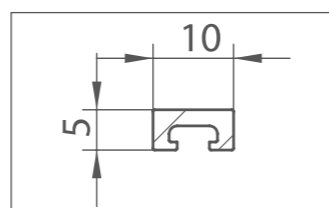

Finitura	Cm 60	Cm 100	Cm 200
	Cod.Prezzo	Cod.Prezzo	Cod.Prezzo
BRUSH NEUTRO	19	32	61
ARGENTO SATINATO	19	32	61
BRONZO SATINATO	31	46	76
BRUSH + OX. BRONZO	45	62	97
Kg/Scatola	0,8	1,4	2,8
PIATTINA 0,3x1 Pz/Scatola	18	18	18
PIATTINA 0,5x1 Pz/Scatola	10	10	10

BATTISCOPA

Caratteristiche

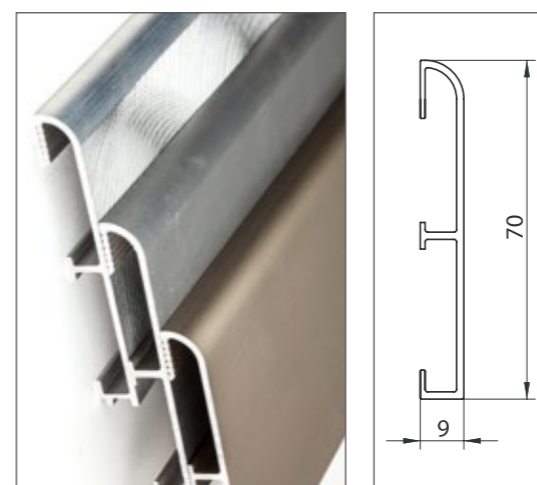

Finitura	Cm 60	Cm 100	Cm 200
	Cod.Prezzo	Cod.Prezzo	Cod.Prezzo
BRUSH	52	69	108
ARGENTO SATINATO	52	69	108
BRONZO SATINATO	58	76	120
TERMINALE ANGOLO 90°	(Brusch - Argento - Bronzo) Cod.Prezzo 41 (Pz scat. 2)		
Kg/Scatola	2,0	3,0	6,0
Pz/Scatola	6	6	6

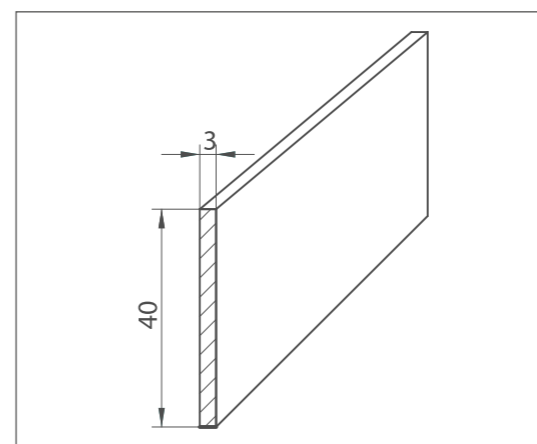

Finitura	Cm 100	Cm 200
	Cod.Prezzo	Cod.Prezzo
BRUSH	63	98
POLISHED	63	98
ARGENTO SATINATO	65	102
Pz/Scatola	10	10

FASCE GLITTER 1x30cm



ARGENTO SAT. + SILVER 01



BRUSH SILVER + SILVER 01



BRUSH SILVER + BURNISHED 26



BRUSH SILVER + RED 07



BRUSH SILVER + VIOLET 03



BRUSH SILVER + BLU 19



BRUSH BRONZO + BRONZO - Cod.Prezzo 06.0008

Articolo	Finitura ALLUMINIO	Formato Cm	Cod.Prezzo/Pz	Pz/scat.	Kg/scat.
Item	Finish Aluminum	Size	Price code/pc	Pcs/box	Kg/Box
06.0600	Brush		52	6	0,5
06.0610	Argento Sat				
06.0620	Argento Brill.				
06.0630	Bronzo Sat.				
06.0640	Bronzo Brill.				
06.0650	Brush+Arg.				
06.1060	Brush+Bronzo				

Per lotti di almeno 100 Pz si eseguono lunghezze a richiesta

PZ/SCAT. 6 - Kg. 1

FASCE MINISTICK



FASCIA STIK BRUSH 2.5 x 30 - Art. 07.0012

Cod. Prezzo 43



FASCIA STIK MIX ARGENTO 2.5 x 30 - Art. 07.0010

Cod. Prezzo 50



FASCIA MIX ARGENTO SAT + ARGENTO LUCIDO 2.5 x 30 - Art. 07.0014

Cod. Prezzo 51



FASCIA STIK BRONZO 2.5 x 30 - Art. 07.0011

Cod. Prezzo 52



FASCIA STIK MIX BRONZO 2.5 x 30 - Art. 07.0013

Cod. Prezzo 54

PZ/SCAT. 6 - Kg. 1,1

FASCE METAL



FASCIA MIX OX ARGENTO 3F 3.5 x 30 - Art. 07.1003

Cod. Prezzo 52

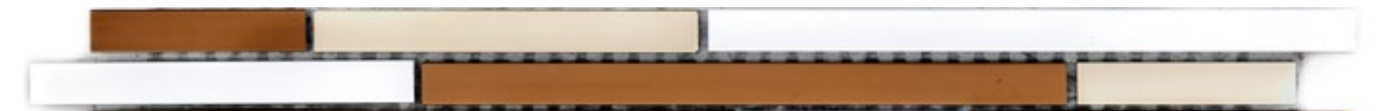

FASCIA MIX OX BRONZO 3F 3.5 x 30 - Art. 07.1004

Cod. Prezzo 52

FASCE GLOSS - 1.0

PZ/SCAT. 6 - Kg. 1,1

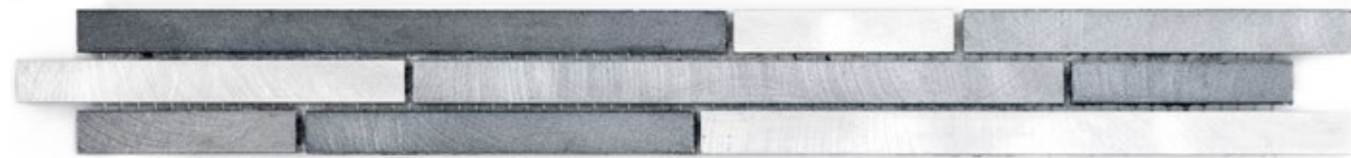

FASCIA GLOSS MIX GREY 3F 3.5 x 30 - Art. 09.1020

Cod. Prezzo 50



FASCIA GLOSS MIX BRONZO 3F 3.5 x 30 - Art. 09.1010

Cod. Prezzo 50

FASCE GLOSS - 1.5

PZ/SCAT. 6 - Kg. 1,1



FASCIA GLOSS MIX BRONZO 5 x 30 - Art. 07.1533

Cod. Prezzo 51

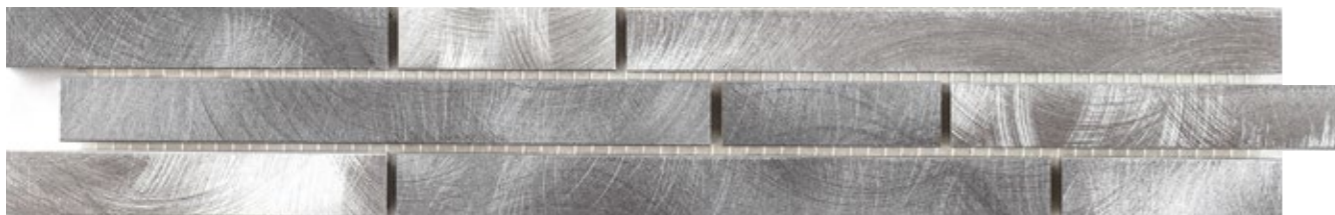

FASCIA GLOSS MIX GREY 5 x 30 - Art. 07.1543

Cod. Prezzo 51

FASCE METAL

PZ/SCAT. 6 - Kg. 1,2



FASCIA MIX OX BRONZO 5 x 30 - Art. 07.1523

Cod. Prezzo 55

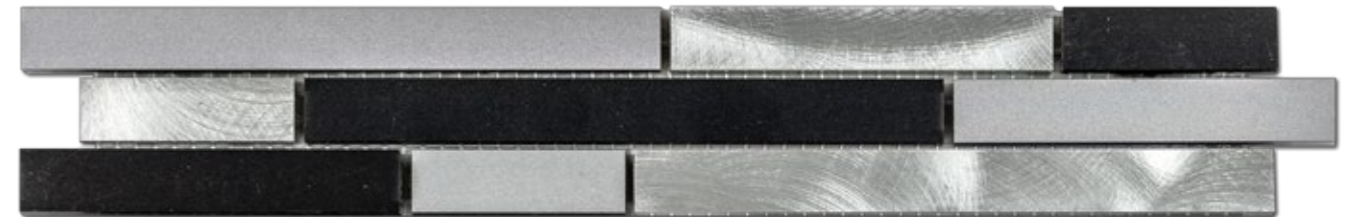

FASCIA MIX OX GREY 5 x 30 - Art. 07.1503

Cod. Prezzo 55

PZ/SCAT. 6 - Kg. 1,2

FASCE BRUSH

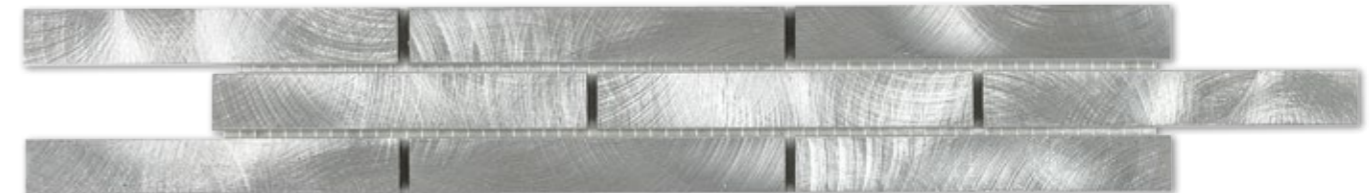

FASCIA BRUSH 5 x 30 - Art. 07.0000

Cod. Prezzo 45

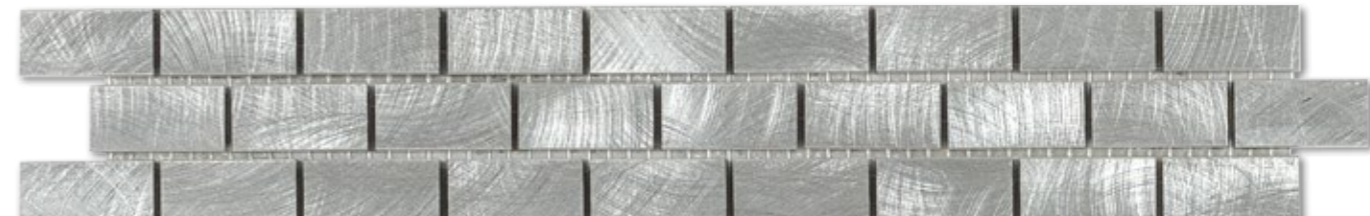

FASCIA MURETTO BRUSH 5 x 30 - Art. 07.0005

Cod. Prezzo 48

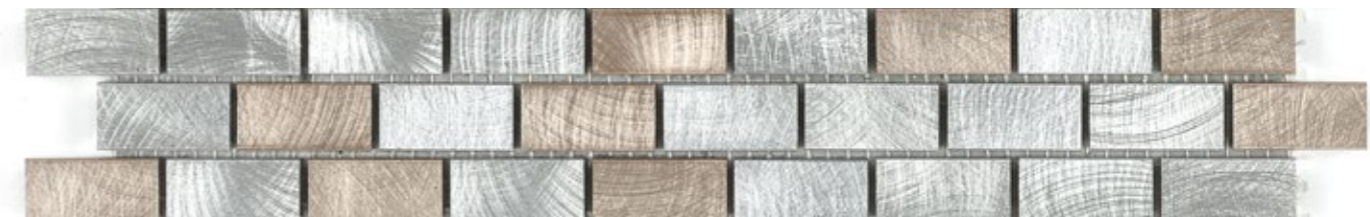

FASCIA MIX BRONZO RANDOM 5 x 30 - Art. 09.0025

Cod. Prezzo 50

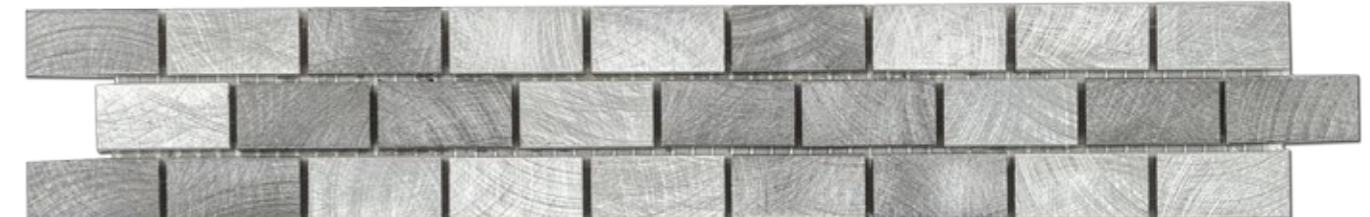

FASCIA MIX GREY RANDOM 5 x 30 - Art. 09.0010

Cod. Prezzo 50

SISTEMI DI POSA

Indicazioni tecniche per la posa in opera di profili in alluminio, mosaici in alluminio, piastrelle in alluminio, decori in metallo per arredamento.

Le colle indicate sono quelle poliuretatiche o epossidiche. In caso di utilizzo di colle cementizie che tendono a creare un "ambiente basico" è **NECESSARIO** limitare il più possibile il contatto con la parte che rimarrà in vista e durante la posa pulire **PRONTAMENTE** con acqua e spugna morbida l'eccesso di colla che va sulla parte in vista.

Anche durante la stuccatura **PRESTARE ATTENZIONE** agli eccessi di fugante. È fondamentale che la pulizia dei residui di stuccatura venga eliminata **IMMEDIATAMENTE**, prima che i prodotti usati inizino a far presa.

Questo per evitare che la rimozione di eventuali residui non creino un danno estetico al materiale. Non utilizzare prodotti abrasivi, acidi e/o basici, ma solo panni e spugne morbide pulite da residui cementizi. Non attendere che il fugante si indurisca/secca.

MANUTENZIONE E PULIZIA

Si consiglia di usare un panno morbido inumidito con acqua e sapone, alcool o detersivi neutri per la casa (non acidi o basici). **Non utilizzare in nessun caso prodotti abrasivi, acidi e/o basici.**

INSTALLATION SYSTEMS

*The indicated glues are polyurethane or epoxy glues. When using cement glues that tend to create a "basic environment", it is **NECESSARY** to limit as much as possible the contact with the part that will remain uncovered during the installation. **PROMPTLY** clean the excessive glue on the uncovered part using water and a soft sponge. **PAY ATTENTION** to the excessive grout during the grouting operation. It is essential to **IMMEDIATELY** remove the grouting residues before the products start to set. This is to avoid a later removal that could damage the material aesthetics. Do not use abrasive, acid and/or basic products, but only clean and soft cloths and sponges with no cement residue. Do not wait for the grout to become hard/dry. For further technical information refer to the technical sheets provided by the manufacturers of adhesives and glues. We recommend using always high-quality products.*

MAINTENANCE AND CLEANING

*We recommend using a soft cloth soaked in soapy water, alcohol or household neutral detergents (not acid or basic). **Never use abrasive, acid and/or basic products.***

INSTALLATION SYSTEMS

*Les colles indiquées sont les colles polyuréthaniques ou époxydiques. Si on utilise des colles à base de ciment qui ont la tendance à créer un « environnement basique », il est **NÉCESSAIRE** de limiter le plus possible le contact avec la partie en vue et durant la pose nettoyer **RAPIDEMENT** avec de l'eau et une éponge douce l'excès de colle sur la partie en vue. Même durant le masticage **FAIRE ATTENTION** aux excès de ciment joint. Il est important que les résidus de masticage soient éliminés **IMMÉDIATEMENT**, avant que les produits utilisés commencent à prendre prise. Cela pour éviter que l'enlèvement d'éventuels résidus ne vont pas à miner l'esthétique du matériel. Ne pas utiliser des produits abrasifs, acides et/ou basiques, mais uniquement des chiffons ou éponges doux sans résidus de ciment. Ne pas attendre que le ciment joint durcisse/sèche. Pour d'autres informations, faire référence aux fiches technique fournies à tous les producteurs de colle et adhésifs. Nous conseillons d'utiliser toujours des produits de qualité.*

ENTRETIEN ET NETTOYAGE

On conseille d'utiliser un chiffon doux mouillé d'eau et savon, alcool et détergents neutres ménagers (exempts d'acides et basiques).

Jamais utiliser des produits abrasifs, acides, et/ou basiques

MATERIALS FOR INSTALLATION AND GROUTING

As far as the floor installation is concerned, we recommend using a conductive adhesive that allows electrostatic induction and floor insulation. In case of floor heating and/or sun direct radiation, we recommend leaving a 5-10 mm "joint" on the room perimeter according to its dimensions.

Among the adhesives commonly available on the market we recommend using:

KERALASTIC: high performance two-component polyurethane adhesive, slip-resistant.

GRANIRAPID: high performance two-component fast setting and hydrating adhesive system.

For the joint grouting we recommend using:

KERAPOXY: two-component acid-resistant epoxy mortar.

ULTRACOLOR PLUS: high performance grout with fast setting and drying, anti-efflorescence properties, mildew-resistant, water-repellent, with Drop Effect technology to grout 2 to 20 mm-joints.

In all cases we recommend to thoroughly read the installation instructions provided by the manufacturer of the adhesive.

MATÉRIELS POUR LA POSE ET LE MASTICAGE

En ce qui concerne la pose au sol, nous conseillons d'utiliser un collant conducteur qui permet l'induction électrostatique et l'isolation du sol. En cas de chauffage au sol et/ou irradiation directe du soleil, nous conseillons de laisser pour la dilatation un « joint » sur le périmètre de la pièce de 5 - 10 mm selon la grandeur de la surface.

Parmi les collants qu'on repère habituellement, nous conseillons:

KERALASTIC: adhésif polyuréthanique à deux composants, résistant au glissement et garantissant hautes performances.

GRANIRAPID: système adhésif à deux composants à prise et hydratation rapide.

Pour le masticage des joints nous conseillons :

KERAPOXY: mortier époxydique à deux composants, exempt de solvants.

ULTRACOLOR PLUS : mortier à hautes performances, anti-efflorescent, pour le masticage des joints de 2 à 20 mm, à prise et séchage rapide, hydrofuge avec DropEffect et anti-moisissure.

En tous cas on conseille de lire attentivement les instructions de pose fournies par le producteur du collant

MATERIALI PER POSA E STUCCATURA

Per quanto riguarda la posa a pavimento, raccomandiamo l'utilizzo di un collante a conducibilità che permetta la conduzione elettrostatica e l'isolamento del pavimento. In caso di riscaldamento a pavimento e/o irraggiamento diretto del sole, consigliamo di lasciare per la dilatazione una "fuga" sul perimetro dell'ambiente di 5 - 10 mm a seconda dell'estensione della superficie.

TRA I COLLANTI CHE SI REPERISCONO ABITUALMENTE CONSIGLIAMO:

KERALASTIC: adesivo poliuretano a due componenti, resistente allo scivolamento, ad alte prestazioni.

GRANIRAPID: sistema adesivo a due componenti a presa e idratazione rapida.

PER LA STUCCATURA DELLE FUGHE SI CONSIGLIA:

KERAPOXY: malta epossidica antiacida a due componenti .

ULTRACOLOR PLUS: malta ad alte prestazioni, antiefflorescente, per la stuccatura di fughe da 2 a 20 mm, a presa ed asciugamento rapido, idrorepellente con DropEffect e antimuffa.

In tutti i casi si consiglia di leggere attentamente le istruzioni di posa fornite dal produttore del collante

CONDIZIONI GENERALI DI FORNITURA



CONDIZIONI GENERALI DI FORNITURA

- I prezzi (cod.prezzi) si intendono al netto di iva e franco fabbrica (nostra sede).
- Il listino ha validità fino al 31/12/2017. Se si dovesse modificare il listino prima della scadenza naturale verrà fatto con un preavviso di almeno 30 g.
- I prezzi indicati si intendono sempre per scatole intere
- Eventuali costi di trasporto verranno addebitati al costo. Il materiale viaggia a rischio e pericolo del committente.
- I prodotti devono essere controllati prima della posa ed eventuali difetti di forma e/o qualità devono essere segnalati entro 8 giorni dal ricevimento della merce ed in ogni caso prima della posa. Non si accettano contestazioni a materiale posato.
- Per qualsiasi controversia e/o contestazione sarà competente il foro di Modena.

GENERAL SUPPLY CONDITIONS

- *The prices (price code) are VAT excluded and ex-works (our headquarters).*
- *The price list shall be considered valid up to 31/12/2017. For any modification of the price list before that date the company provides at least a 30-day notice.*
- *The prices are always intended for full boxes.*
- *Any transportation cost will be added to the product price. The Customer is responsible for the material transportation.*
- *All products shall be checked before their installation and any shape and/or quality fault must be communicated within 8 days from the good reception and anyway before their installation. No claims will be accepted after the products have been installed.*
- *Any dispute and/or claim will be submitted to the Court of Modena.*

CONDITIONS GÉNÉRALES DE FOURNITURE

- *Les prix (codes des prix) sont hors TVA et départ usine (notre siège)*
- *Les tarifs sont valides jusqu'au 31/12/2017. Si les tarifs sont modifiés avant la date ci-dessus nous donnerons un préavis d'au moins 30 jours.*
- *Les prix ici indiqués se réfèrent aux boîtes complètes.*
- *Le coût sera déduit des coûts éventuels de transport. Les risques et périls du transport du matériel sont à la charge du client.*
- *Les produits doivent être contrôlés avant la pose et les défauts éventuels liés à la forme et/ou qualité doivent être signalés dans 8 jours à partir de la réception de la marchandise et en tout cas avant la pose. On n'accepte pas des réclamations si la pose a été déjà réalisée.*
- *Pour tout litige et/ou contestation le tribunal compétent sera celui de Modène*

Tutte le immagini e le ambientazioni sono puramente dimostrative. I toni possono subire variazioni essendo tutti prodotti artigianali.

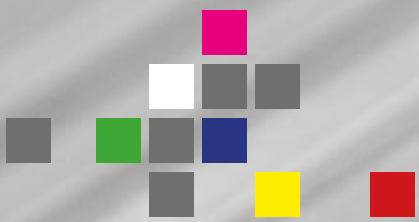

Via S. Vito 503 - 41057 Spilamberto (MO)
Tel. + 39 059 785254 - Fax + 39 059 7861543 - info@cromie.eu

www.cromie.eu